

## Fully Automatic Stacker Slicer Model VA 2000

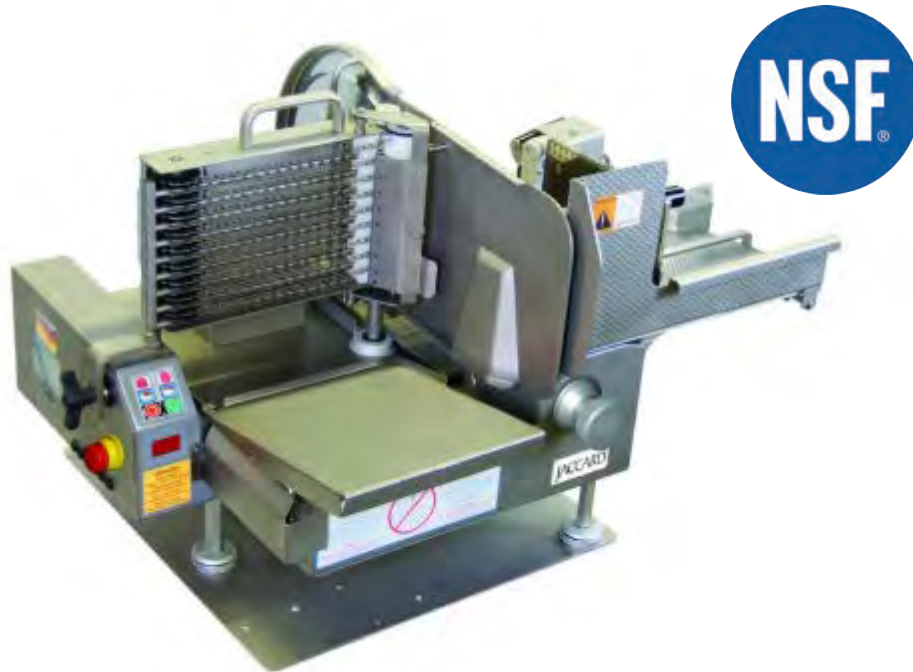

*[Click here to watch video](#)*

- World's only Stacker Slicer certified by NSF standards
- Patented Chain Drive Assembly which was deemed unclean-able by NSF, now Dishwasher Safe
- Single Ventilated / Varnish Coated PC Board system extends machine life and durability
- Angled carriage design to facilitate easy slicing /discharge of low height products
- Maintenance free gear motor

World's only  
Stacker Slicers  
approved by the  
**National Sanitation  
Foundation\***

NSF

## VA2000 Stacker Slicer



[Click here to watch video](#)

As the only patented slicer with an Easy to Clean Chain Drive, which reduces the tearing of sliced meats and cheeses, customers will see an increase in productivity, product quality and overall decrease in food cost. The VA2000 is the safest machine on the market and adheres to the strictest food safety guidelines while being certified by NSF.



### KEY FEATURES

#### Machine Construction

- Stainless steel provides enhanced longevity and durability, eliminates oxidation, potential for food contamination and is easier to clean

#### Cost of Ownership

- Patented chain drive assembly extends chain life.
- Powered by a single ventilated / varnish coated PC board
- Automatic fan system eliminates condensation build up
- Minimization of wearable parts

#### Cleaning

- Patented chain drive assembly, liquid diversion system and removable product advance system make the VA2000 Dishwasher Cleanable, all metal parts in contact are stainless steel

#### Stacking & Slicing Versatility

- Automatic stacking and shingling of slices eliminates wear and tear on operators' arms and shoulders

\*NSF certification is your key to making sure that the products you use meet strict standards for public health protection. Competitors may claim to be "certified to NSF standards" "meets criteria of NSF standards" and similar statements. These claims do not qualify as legitimacy of NSF certification nor have they complied with the strict standards and procedures imposed by NSF

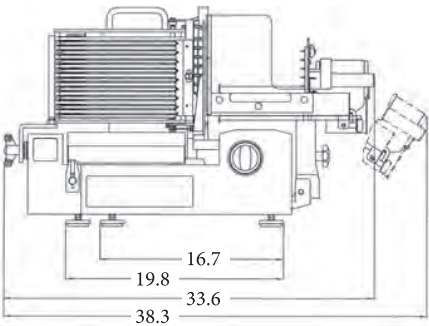
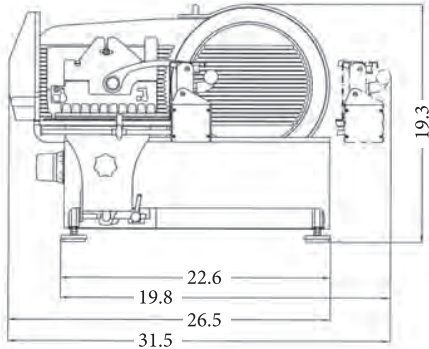

**The VA2000 is available in the following configurations:**

**Teflon coatings**  
 Ideal for various applications (including cheese, bacon, ...)

**No smearing or sticking**

**Foulings are reliably prevented**

**Quick and easy cleaning**

**with Bench / Stand (fixed) stainless steel**  
 (L x W x H)  
 29.1 x 25.6 x 26.4 in

**with Bench / Stand (rollable) stainless steel**  
 (L x W x H)  
 29.1 x 25.6 x 26.4 in

**TECHNICAL SPECIFICATIONS**

**Footprint:**  
 (l x w) 22.6" x 19.8"

**Dimensions:**  
 (l x w x h) 26.5" x 33.6" x 19.3"

**Carriage:**  
 (l x w): 21" x 10.8"  
 when product gripper in use  
 (l x w): 16" x 10.8"

**Weight:**  
 Approx. 166 lb.

**Power:**  
 120 V single-phase

**Blade:**  
 13 in, standard stainless steel

**Slice Thickness:**  
 0 - .40 in

**Cutting Length:**  
 10.0 in

**Max. Cutting Width:**  
 7.7 in

**Cutting Height:**  
 7.5 in

**Cutting Speed:**  
 Adjustable - approx. 25 - 50 strokes per minute

**STACKING**

maximum stack height 3 in.

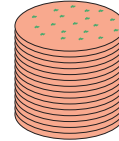

**SHINGLING**

1-9 layer automatically, shingling distance can be preset

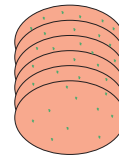

VA 2000

**F.I.R.S.T. – Flexible, Integrated, Responsive, Service, Training Program**

The F.I.R.S.T Training Program provides customers to the CFESA network of over 3,000 certified technicians that provide the highest level of training and service in the industry.

## Stacker Slicer Competitive Comparison

Feature	Jaccard	Competitor	Comments
	YES	NO	Jaccard VA2000/4000 series slicers are the world's only stacker slicer certified by NSF
Machine Construction	Stainless Steel	Anodized Aluminum	Stainless steel provides enhanced longevity & durability, eliminates oxidation, potential for food contamination and is easier to clean
Cost of Ownership	Low	High	Single ventilated/varnish coated PC board vs. competitions' six PC board design, minimization of wearable parts and patent pending chain drive assembly
Cleaning	Easy	Difficult	Patent chain drive assembly, liquid diversion system and removable product advance system make the VA2000/4000 Dishwasher Cleanable
Slicing Versatility	Broad	Limited	Patent pending angled carriage design and 9 chain product gripping system (vs competitor 6 chain) capable of slicing very low height products. Jaccard carriage also has a 15mm height and width capacity advantage
Stacking Versatility	Yes	Yes	Each capable of up to 4 stacked rows, circular and cross shingled output. VA4000 up to 9 shingle rows – competitor only 3 rows
Programmable	Yes	Yes	Both capable of storing up to 99 programs. VA4000 QuickTime Programming™ allows upload/revision through patent pending disc drive