

# KT-ALP

## Commercial Meat Press/Flattener

KT-ALP



# KT-ALP MEAT PRESS/FLATTENER

## KEY FEATURES

- High quality stainless steel construction
- Semi-automatic mechanical meat press that quickly flattens fresh or chilled meat without loss of juices or weight. Ideal for poultry, beef, pork or veal within small to medium production operations.
- Patented design ensures meat retains flatness indefinitely.
- Uniform thickness guarantees even cooking and greater plate coverage for optimal presentation
- Pressed meat is a consistent and even thickness and stays juicy when fried.
- Thickness of end product is adjustable through a thickness adjustment between 1.0mm to 30.0mm
- Fast and efficient - pressing up to 800 steaks per hour at a working pressure of 3000 kg
- Serrated flattener plate provides tenderization of product within the flattening operation and additional area for breading or coating applications
- Optional smooth press plate - optional



# TECHNICAL SPECIFICATIONS

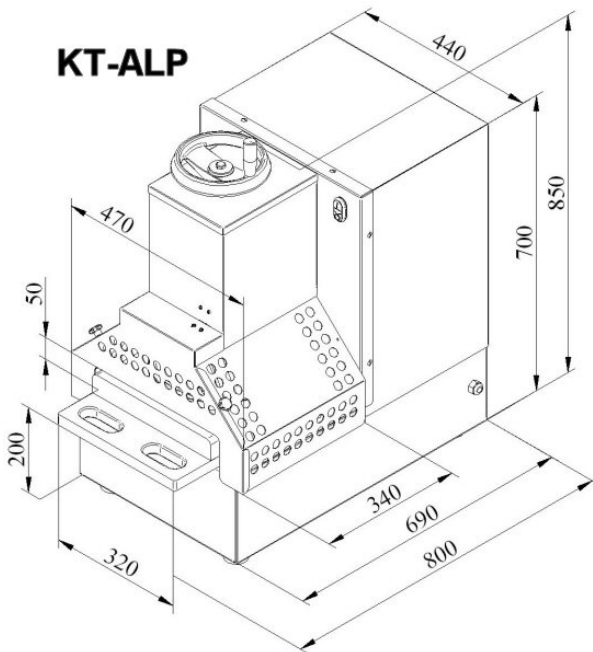

**Dimensions:** (w/out stand)  
32.09" H x 19.69" W x 28.74" D  
**Motor:** 2hp  
**Machine Weight:** 385 lbs  
**Voltage Requirements:** 220v/3 phase

Maximum Output Capacity (pieces per hour)	800
Adjustable Flattened Product Thickness	1.0 mm to 4.5 mm
Maximum Product Width	10.83 in/275 mm
Stepless Working Pressure Adjustment (bar)	50 to 200
Maximum Adjustable Pressure Force	6,600 lbs/3,000 kg
Pressing Plate Diameter	11 in/280 mm

Stainless Steel Construction	Std
Full Magnetic Safety & Security System	Std
Low Voltage Electronic Controls	Std
"Plug n' Play" Design	Std
No Tool Requirement for Inspection or Cleaning	Std
Two Hand Safety Start Up	Std
Removal of Parts for Easy Clean-Up	Std
Pressure Gauge	Std
Serrated Press Plate	Std
Smooth Press Plate	Opt
Locking Wheel Stainless Steel Stand	Opt



## Who we are...

### Since 1962,

Jaccard® Corporation has been providing innovative and compelling products to the consumer retail, food service, and food processing markets. Jaccard Corporation founder, Swiss Master Butcher and industry icon, Andre Jaccard, knew that creating compelling and useful products that people wanted was the key to running a successful business. Today, Jaccard operates by these same principles – we are busy refining existing products and developing new ones with the same desire to provide our customers with the best possible solutions to their everyday needs.