



**Known for Reliability  
Since 1921**



Model 346SS  
Shown Standard

The Biro 346SS is a compact stainless steel manual feed grinder that is well suited to today's smaller meat rooms. Its 3 HP motor has plenty of power, and the size 32 head and square throat bowl ensure plenty of productivity. The single reduction roller chain drive ensures maximum power, and the tapered bearings mean trouble-free operation. The bowl assembly and feed tray are easily removed without tools, so cleanup is a snap. Efficiency, durability, and low, low maintenance all help make the Biro 346SS Meat Grinder a reliable workhorse you can depend on.

1/8" (3.2 mm)



3/8" (9.5 mm)

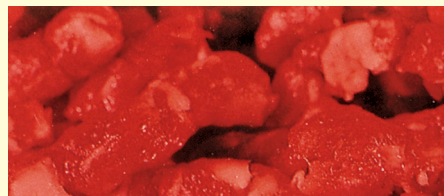

**346SS**

# MODEL SPECIFICATIONS

**Model: 346SS Grinder (chopper, mincer).**

**Motors:**

HP	TYPE	KW	VOLTS	AMPS	CYCLE	PH	STATUS
3	ODP	2.2	208-230/460	15-14/7	60	3	STD
3	ODP	2.2	208-220	18-17	60	1	EC
3	ODP	2.2	200	11.5	60	3	EC
3	ODP	2.2	575	3.7	60	3	EC
3	ODP	2.2	220/380	12.1/7	50	3	EC
3	ODP	2.2	220-230	19-18	50	1	EC

ODP = Open Drip Proof    STD = Standard    NC = No Charge  
EC = Extra Charge



**Construction:** Stainless steel feed pan and polished stainless steel case, cast iron hot tin-dipped bowl assembly, size 32.

**Switch:** Watertight enclosure, magnetic, thermal overload type, automatic resetting, switch controlled by a rocker rod arrangement projecting outside both sides of machine activated by switch rod handle.

**Power Cord:** Available option at extra cost.

**Capacity Feed Pan:** Approximately 85 lbs. (38.5 kg).

**Grinding Capacity:**

1st grind 3/8" (9.5 mm) plate output is 45 lbs. (20 kg) per minute.

2nd grind 1/8" (3.2 mm) plate output is 29 lbs. (13 kg) per minute.

NOTE: Outputs are approximate depending on product temperature, fat-lean ratio, feed speed, texture, sharpness of knife and plate.

**Drive System:** Pre-lubricated chain drive.

**Safety:** Magnetic safety interlock so machine will not operate when feed pan with welded bowl guard is removed.

**Standard Features:** 11" (280 mm) aluminum legs • splash guard • stomper • ring wrench • welded bowl guard on feed pan • operating and safety manual.

**Options (EC):** Size 32 knife and plate • longer legs • power cord • 220/380-50-3 • 220-50-1 • stainless steel bowl assembly (enterprise or unger) • solid stomper • right hand feed pan.

**Certification:** U.S.D.A., N.S.F., U.L. - 3 phase.

**Weight:**

1 phase uncrated: 344 lbs. (156 kg.) approximate.

1 phase crated: 432 lbs (196 kg.) approximate.

3 phase uncrated: 345 lbs. (157 kg.) approximate.

3 phase crated: 435 lbs (198 kg.) approximate.

**Dims. Crated:**

L = 30" (762 mm), W = 59" (1499 mm), H = 41" (1041 mm).

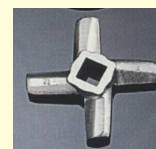

Optional (EC) size 32 knife and plate. Plate hole sizes available, other hole sizes not listed available upon request.

- MC32-17 Knife, 4 Blade
- MC32-18-125 Plate, 1/8" Holes (3.2 mm)
- MC32-18-156 Plate, 5/32" Holes (4.0 mm)
- MC32-18-187 Plate, 3/16" Holes (4.3 mm)
- MC32-18-375 Plate, 3/8" Holes (9.5 mm)

Do not use grinding plates with 1/2" (12 mm) or larger holes. Recommend 3/8" first grind, 1/8" second grind.

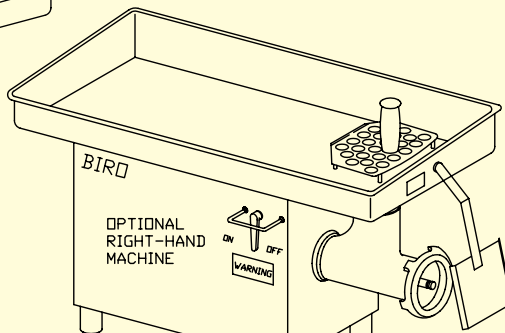
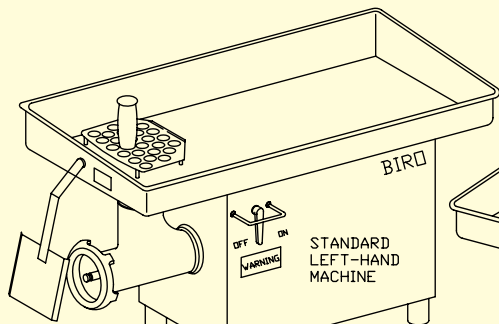
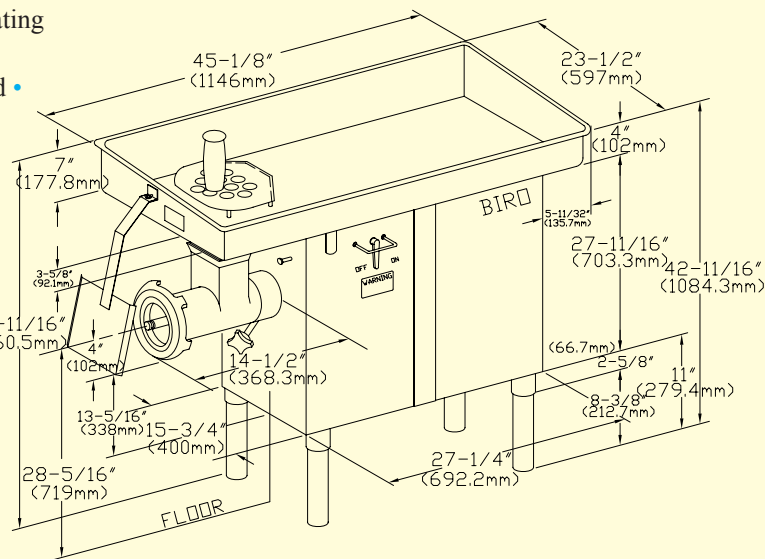

**BIRO MANUFACTURING COMPANY**  
1114 WEST MAIN STREET  
MARBLEHEAD, OH 43440-2099 U.S.A.

Phone: (419) 798-4451

Fax: (419) 798-9106

<http://www.birosaw.com>

[sales@birosaw.com](mailto:sales@birosaw.com)

ITEM NO.: LIT-346-204

FORM NO.: Md 346-7-15-15-B

All specifications contained herein are subject to change without notification.

Service is available from locations worldwide