



Known for Reliability Since 1921

The 5 HP (3 Kw) motor provides all the power you need to break pork, lamb, veal, or beef all day in a high volume production operation. Heavy duty, stainless steel construction helps the Model 55 hold up under the harshest conditions with minimum maintenance. With the standard front moving carriage and meat gauge plate and 20" H (508mm) by 21" D (533mm) cutting clearance, you can use the same saw to produce retail cuts or split loins and break quarters, which makes the Model 55 unmatched for versatility. Superior BIRO engineering means you'll have a saw that's built to last. Over the life of the saw, you'll get more for your money. As with all BIRO products, if you need a particular modification to fit your application let us know. We'll try to build it for you - something only BIRO does.



STANDARD RIGHT TO LEFT
FEED CONFIGURATION
(FRONT MOVING CARRIAGE
AND STATIONARY REAR TABLE)



RIGHT TO LEFT FEED CONFIGURATION
(OPTIONAL STATIONARY
FRONT AND REAR TABLES)

55

MODEL SPECIFICATIONS

Model: 55 Power Cutter (Breaking saw - 22")

Construction: Heavy duty stainless steel 8 Gauge (4.2mm) base and fixed head.

Motors:

HP	TYPE	VOLTS	AMPS	CYCLE	PH	STATUS
5	TEFC	208-230/460	14.3-12.9/6.45	60	3	STD
5	TEFC	380	7.74	50	3	STD
5	TEFC	220/380-415	17.8/10.3-9.4	50	3	EC
5	TEFC	575	5.9	60	3	EC
7.5	TEFC	208-230/460	20-19/9.5	60	3	EC

TEFC = Totally Enclosed Fan Cooled STD = Standard
NC= No Charge EC = Extra Cost

Standard Features: Two saw blades, operation and parts manual, safety wall poster, end cut safety pusher plate.

Switch: Watertight magnetic with thermal overload and under voltage protection.

Head and Door: Stainless steel fixed head, removable head door.

Blade Standard: Hard tooth, three teeth per inch (8.5 mm between teeth), 164.5" (4178.3 mm) long x 3/4" (19 mm) wide, .022" (.56 mm) thick (two supplied with each saw).

Blade Speed: 3880 feet (1182 m) per minute approx.

Blade Back-up Guides: Upper and lower blade backup guide assemblies, removable, with long life carbide back-up inserts.

Blade Tension: Factory preset spring with screw handle assembly.

Blade Wheels: 22" (55.8 cm) cast iron, chrome nickel plating, upper wheel assembly lifts out.

Bearings: Heavy duty tapered roller bearings used in upper wheel and lower bearing housings.

Catch Pan: Stainless steel pan sealed off from other parts of base, accessible through base hinged door.

Cleaning Unit: Stainless steel body, long life carbide guide insert, stainless steel saw cleaners, removable as a unit for easy cleaning (assembly also adjustable as a unit).

Drive System: Non slip silent v-belt, tension adjustable.

Legs: Stainless steel legs with discs, adjustable.

Meat Carriage: Stainless steel, EZ-flow movement with ten stainless steel bearings.

Meat Gauge Plate: Stainless steel faced, adjustable from 1/16" (1.59 mm) to 6-1/2" (165 mm) locks in position, can be disengaged, entire assembly removable for cleaning.

Motor Compartment: Sealed off from meat contact areas, easily accessible through removable panel door.

Rear Platter: Split, two piece stainless steel, held in place with push pull hold down stainless steel rod and two knobs for easy removal.

Safety End Cut Pusher Plate: Standard, removable, pusher plate storage hanger provided.

Options (EC): Left to right feed, front moving carriage (opposite of standard), Less meat gauge thickness plate assembly
BOTH RIGHT TO LEFT & LEFT TO RIGHT FEED SAWS HAVE
OPTIONAL CONFIGURATIONS: Front and rear stationary tables • front and rear moving tables • front and rear roller top tables (not shown) • cord and plug (specify cord length) • stainless steel saw blade wheels.

Options (NC): Blade speed: 4200 feet (1280 m), 5000 feet (1524 m) per minute.

Certification: U.S.D.A.

Standard configuration
(Right to Left), with
Front moving carriage,
Stationary rear table & Meat
gauge thickness plate assembly.

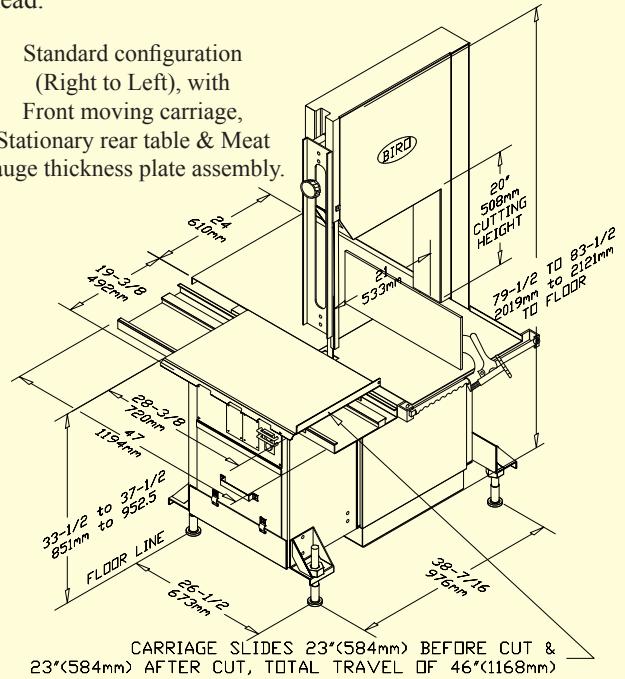

CARRIAGE SLIDES 23"(584mm) BEFORE CUT & 23"(584mm) AFTER CUT, TOTAL TRAVEL OF 46"(1168mm)

Right to Left feed, with
Double (Inside & Outside)
moving tables.

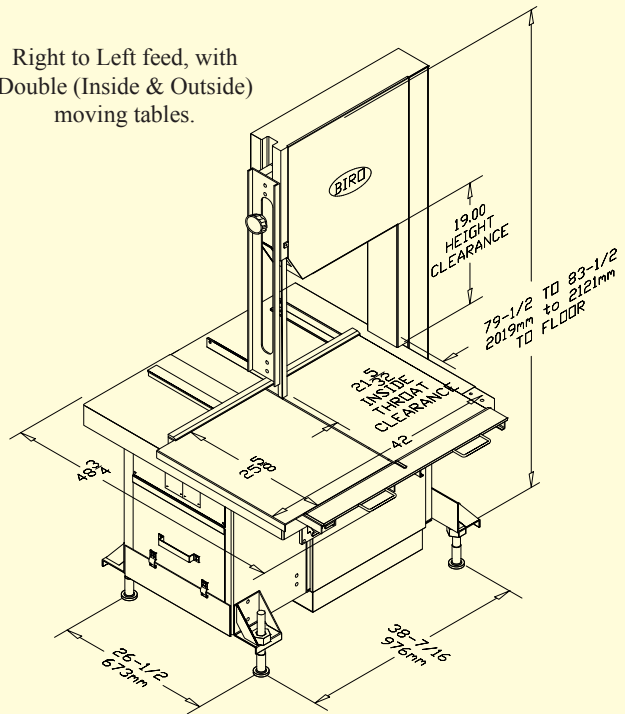

Weight: Uncrated: 885 lbs. (401 kg.) approximate.
Crated: 1250 lbs (567 kg.) approximate.

Dims. Crated: L = 60" (152.4 cm), W = 62" (157.5 cm),
H = 88" (223.5 cm).

BIRO MANUFACTURING COMPANY

1114 WEST MAIN STREET

MARBLEHEAD, OH 43440-2099 U.S.A.

Phone: (419) 798-4451

<http://www.birosaw.com>

Fax: (419) 798-9106

sales@birosaw.com

ITEM NO.: LIT-55-289

FORM NO.: LIT-55-289-9-19-8 B

All specifications contained herein are subject to change without notification.

Service is available from locations worldwide