



Known for Reliability Since 1921

The BIRO Semi-Automatic Slicers are designed to provide trouble free service in a wet meat room environment. Features such as Water Resistant Motors, Electrical Components and Connections, plus Non Corrosive Metals all add to the water protection benefits of the slicer.

The new B350Comfort utilizes a single speed motor capable of slicing up to 40 slices per minute with a full stroke of the carriage. It also is equipped with a disengagement lever to easily switch from automatic to manual operation.

The B350A Automatic slicer operation provides an auto piece count selection range of 0-99 pieces with automatic shut-off. It is equipped with an adjustable ten speed motor that can be adjusted during operations while providing three stroke length options to accommodate varying product sizes.

The 13 $\frac{3}{4}$ " (350mm) Dia. blade, common to both machines, is a Hollow Ground Alloy Steel blade. It is designed with a special step face to relieve surface friction on the products that allows for a slicing capacity of 9 $\frac{1}{4}$ " (235mm) on round products. The thickness control allows for cuts from 0-1" (25mm) with indicator positions shown on the index knob in 1 mm increments, providing precise slice consistency.

Minimal number of removable parts allow for easy clean up while the ergonomic and easy glide carriage allows little resistance during manual slicing.

Built in safety features include: Blade protective ring guard, which prevents exposing the blade's edge when the blade cover is removed for cleaning. When the table is locked open for cleaning it prevents the thickness gauge from being opened exposing the blade edge. The remote sharpener mounts easily when needed, but is stored away from the slicer when not in use, providing added hygiene security to the slicing operation.



B350Comfort



B350A

B350Comfort / B350A

MODEL SPECIFICATIONS

Models:	B350Comfort Semi-Automatic single speed slicer	B350A Semi-Automatic multi speed slicer
Construction:	Body - anodized polished aluminum cast with non-corrosive metal frame	
Motors:	IP65 ½ HP (.37kW) 115V 60hz 1ph, Internally Cooled, Water Resistant (standard, U.S. voltage) IP65 ½ HP (.37kW) 220V 60hz 1ph, Internally Cooled, Water Resistant IP65 ½ HP (.37kW) 220V 50hz 1ph, Internally Cooled, Water Resistant	
Standard Features:	Blade 13¾" (350mm) Hollow ground alloy steel (240 rpm) • Slice thickness adjustable 0-1" (0-25mm) • Maximum product cut, Round 9¼" (235mm) • Maximum product cut, Square 7⅞" x 7⅞" (200mm x 200mm) • Maximum product cut, Rectangle 11¼ x 6" (298mm x 152mm) • Automatic spring loaded drive belt tensioning • Blade protective ring guard prevents exposed blade edge during cleaning • Tilt-away product table lockout prevents thickness gauge from opening during cleaning • Thermal overload/no volt release prevents accidental turn on after power outages • Poly groove belt drive providing optimum performance • Water resistant IP65 motor, wiring harness and electronic controls • Product fence-for use on narrow products • Stainless steel product end weight • Machine lift handle to allow cleaning table under machine • 6 ½' cord, 3 prong plug on 115V - 60 • 6 ½' cord, less plug on 220V • Detachable sharpener.	
Automatic Operation:	Single speed at 40 strokes/min. Full length stroke only Green start touch-button with green/blue indicator light, red stop touch-button	Ten adjustable speeds Three adjustable stroke lengths Multi-function keypad with slice counter
Certifications:	NSF8-2010, ETL, CE	
Dimensions: Note, * is the depth w/ full travel of meat carriage	*D 31 ⅜" (797mm) x W 24" (610mm) x H 28¼" (718mm) Foot to Foot (centerline) D 21¼" (540mm) x W 15 ½" (394mm)	*D 31 ⅜" (797mm) x W 24" (610mm) x H 25 13/16" (656mm) Foot to Foot (centerline) D 21¼" (540mm) x W 15 ½" (394mm)
Weight:	Wood Crated: 160 lbs (72.6kg) Approx.	Wood Crated: 160 lbs (72.6kg) Approx.
Crate Dims:	Wood Crated: 33" (838mm) x 30" (762mm) x 33" (838mm) Approx.	Wood Crated: 33" (838mm) x 30" (762mm) x 33" (838mm) Approx.

B350Comfort

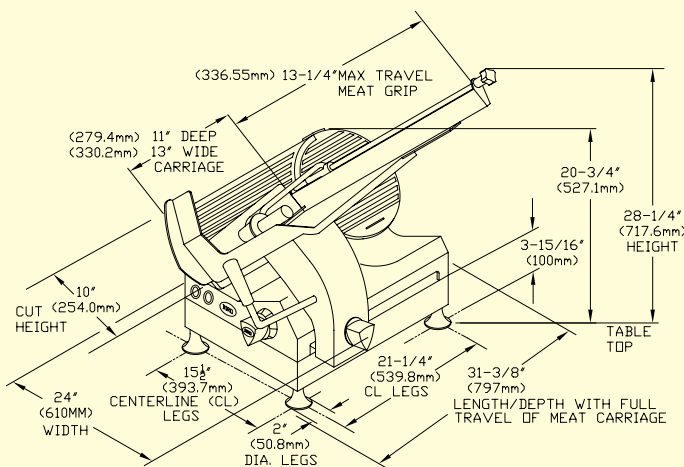

B350A

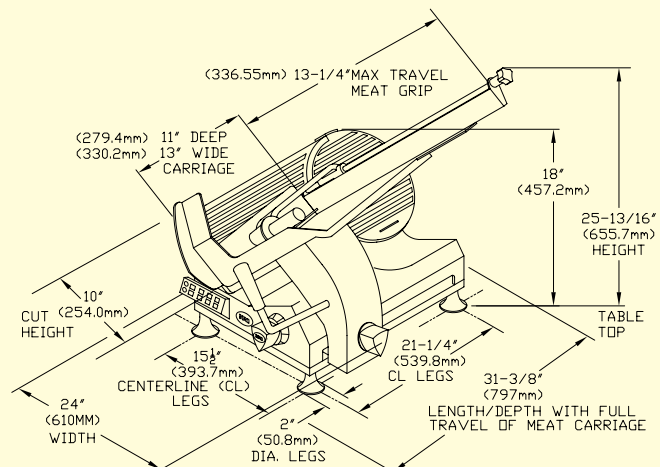

BIRO MANUFACTURING COMPANY
1114 WEST MAIN STREET
MARBLEHEAD, OH 43440-2099 U.S.A.

Phone: (419) 798-4451 • Fax: (419) 798-9106

www.birosaw.com • sales@birosaw.com

ITEM NO.: LIT-B350A/Comfort-372

FORM NO.: Md B350A/Comfort-372-8-15-2-B

All specifications contained herein are subject to change without notification.

Service is available from locations worldwide