



# Known for Reliability Since 1921

By using the BIRO Model AFMG-56MKIII Mixer-Grinder, you can start increasing the output of your grinding operation without having to spend a fortune.

The 800 lb. (362.9 kg) hopper gives you the kind of capacity you need; the 20HP (15 kW) auger motor gives you the power you need. The 5HP (3.7 kW) mixer motor is strong enough that it won't bog down with a full hopper; the twin mixing paddles give you a thorough mix. Safety interlocks and a pneumatic lift for the lid help ensure safety; the machine has watertight controls and totally enclosed motors so you can do a full wash-down cleanup. The hopper and frame are constructed of heavy duty stainless steel so it resists damage and corrosion. As with all BIRO designed and built machines, you get the benefit of over 90 years of engineering experience in building meat processing equipment.

1/8" (3.5 mm)



3/8" (9.0 mm)

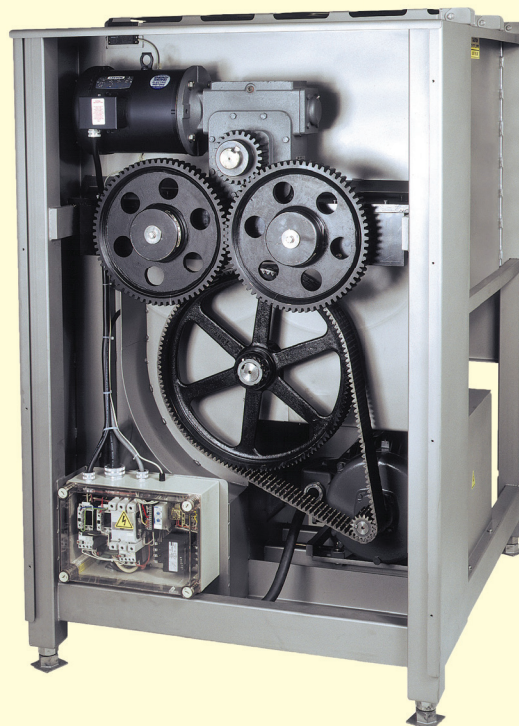

# AFMG-56 MK III

# MODEL AFMG-56MK III SPECIFICATIONS

**Model:** AFMG-56MK III Auto-Feed Mixer-Grinder

**Construction:** Heavy duty stainless steel hopper, lid, paddles, frame and legs. Stainless steel Size 56 bowl, ring and auger.

**Motors:** TEFC= Totally Enclosed Fan Cooled

MOTOR	HP	KW	TYPE	VOLTS	AMPS	CYCLE	PH	STATUS
AUGER	20	15	TEFC	208-230/460	53-48/24	60	3	STD
MIXER	5	3.7	TEFC	208-230/460	14-13/6.6	60	3	STD
AUGER	20	15	TEFC	200	55	60	3	EC
MIXER	5	3.7	TEFC	200	15.9	60	3	EC
AUGER	20	15	TEFC	575	26	60	3	EC
MIXER	5	3.7	TEFC	575	5.2	60	3	EC
AUGER	20	15	TEFC	220/380-415	56/29.3-27	50	3	EC
MIXER	5	3.7	TEFC	220/380-415	14/8.1-7.4	50	3	EC

EC = Extra Charge    NC = No Charge    STD = Standard

**Switch:** Watertight magnetic controller with thermal overload and under voltage protection; separate mix and grind controls; product mix timer is factory preset for 2 minutes mix and 5 minutes off sequence.

**Power cord:** Wired on the low side (200-240) volt operation:

9' (2.7 m) No. 4 GA. wire conductor Power Cord – less plug.

Wired on the high side (380-480) volt operation:

9' (2.7 m) No. 8 GA. wire conductor Power Cord – less plug.

Wired (575) volt operation:

9' (2.7 m) No. 10 GA. wire conductor Power Cord – less plug.

**Hopper Capacity:** Up to 800 lbs. (363 kg).

**Grinding Capacity:** Up to approximately 250 lbs. (113 kg) output per minute.

**Drive systems:** Auger – 20HP (15 kW) T.E.F.C. industrial motor, single reduction silent chain.

Mixer feed paddles – 5HP (3.7 kW) T.E.F.C. heavy duty double reduction gear box and heavy duty open face gear drive.

**Safety:** Magnetic safety interlock on hopper lid.

**Standard Features:** Hopper without side feed inlet • preset pneumatic (45 P.S.I.) lid opener on right side (when facing bowl) • stainless steel spurt guard • ring wrench • operating and safety manual • 11" (280 mm) stainless steel adjustable threaded legs mounted on floor pads. *NOTE* - If machine is raised to 8" (203 mm) or more of exposed threads, the machine must have reinforcing cross leg brace (#60142NE).

**Options (NC):** Pneumatic lid opener (45 P.S.I.) on left side (when facing bowl).

**Options (EC):** Size 56 knife and plate • 6" (152 mm) diameter swivel side lock castors • 11" (280 mm) stainless steel adjustable studs mounted on castor pads. *NOTE* - If machine is raised more than 8" (203 mm) of exposed thread a stainless steel cross brace (#60142NE) is required. Hopper view, fold up step on left or right side 18" Wide (46 cm) x 19-3/4" Deep (50 cm) • continuous feed grill style lid (in place of std. flat lid), right or left lid opening • also available with conveyor product feed chute mounted on right, rear or left side of grill lid.

**Tandem Options (EC):** Requirements for Tandem Operation: Size 56 to 56 right or left side hopper 90° product feed inlet • Size 56 to 56 discharge horn, horn seal, and connecting bracket • 14" (35.6 cm) O.A.L. adjustable leg assembly mounted on 4 castor pads (cross brace and castors required, see above options).

**Certification:** C.F.I.A.

**Weight:** Uncrated 1800 lbs. (817 kg) approx.

Wood crated: 2526 lbs. (1146 kg) approx.

**Crated Dims:** L = 73" (185 cm),

W = 65" (165 cm),

H = 82" (208 cm).

**BIRO MANUFACTURING COMPANY**

**1114 WEST MAIN STREET**

**MARBLEHEAD, OH 43440-2099 U.S.A.**

**Phone: (419) 798-4451**

**http://www.birosaw.com**

**Fax: (419) 798-9106**

**sales@birosaw.com**

All specifications contained herein are subject to change without notification.

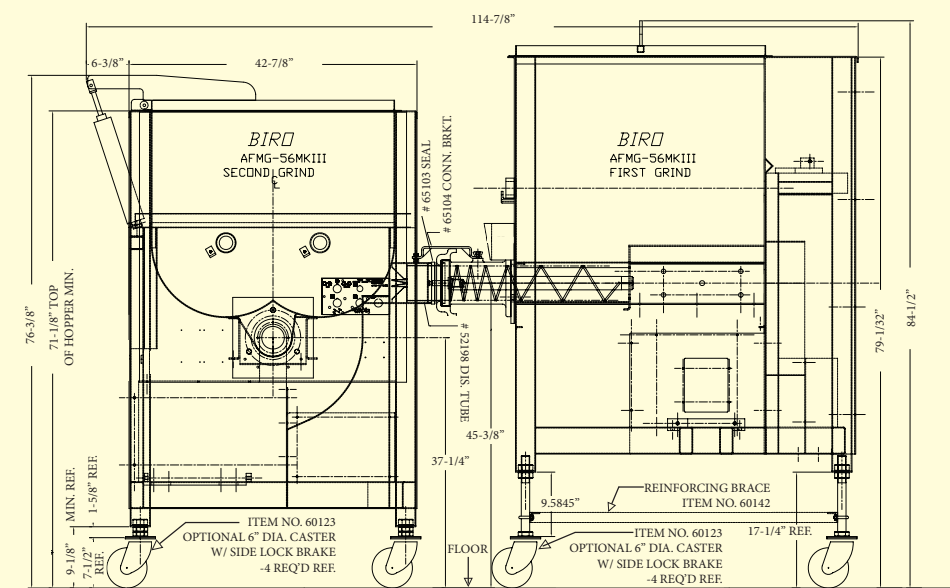
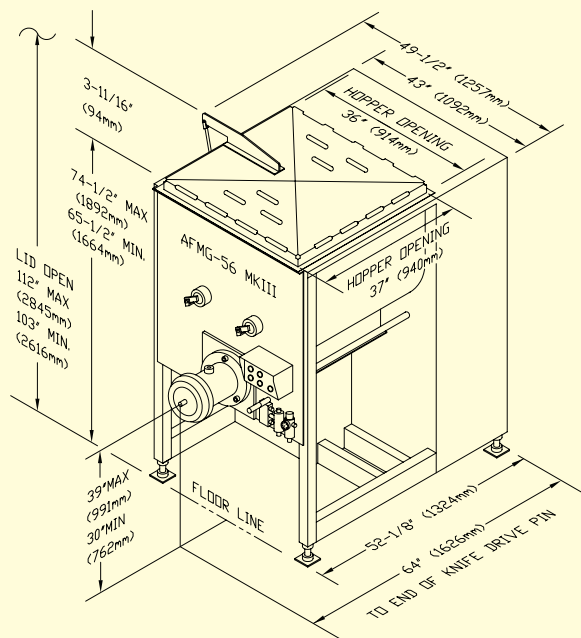

AFMG-56 MK III to AFMG-56 MK III Tandem System

ITEM NO.: LIT-AFMG-56 MK III-309

FORM NO.: AFMG-56 MK III-309-7-14-5-B

Service is available from locations worldwide