



Known for Reliability

Since 1921

The Biro Model AFMG-48-II (Auto-Feed Mixer-Grinder) is a workhorse for medium volume meat operations. Its 7.5 hp (5.6 kw) auger motor and size 48 head, which uses size 32 knife and plate, can give an output of over 65 lbs. (30 kg) per minute for the productivity you need.

The heavy duty roller chain auger drive system with tapered roller bearing journal box is separate from the heavy duty mixer motor interface gear drive system. This more efficient design transfers maximum torque power to the auger. The heavy duty stainless steel 200 lb. (91kg) hopper and frame resist corrosion and damage, even in an environment of harsh cleaners. Your mixer grinder lasts longer and gives you more return on your investment. Power, durability, and low maintenance makes the Biro Model AFMG-48-II Auto-Feed Mixer-Grinder a meat room workhorse.



MODEL AFMG-48-II
AUTO FEED MIXER GRINDER
(Standard Hopper No Inlet)

1/8" (3.5 mm)



3/8" (9.0 mm)



AFMG-48-II

MODEL AFMG-48-II SPECIFICATIONS

Model: AFMG-48-II Auto-Feed Mixer-Grinder

Construction: Heavy duty stainless steel hopper, lid, paddle, frame and legs.

Cast iron hot tin dipped bowl, ring and auger (uses size 32 knife/plate.)

Motors: TEFC = Totally Enclosed Fan Cooled

MOTOR	HP	KW	TYPE	VOLTS	AMPS	CYCLE	PH	STATUS
AUGER	7.5	5.6	TEFC	208-230/460	24-22/11	60	3	STD
MIXER	1.75	1.3	TEFC	208-230/460	5.7-5.2/2.6	60	3	STD
AUGER	10	7.5	TEFC	208-230/460	31-28/14	60	3	EC
AUGER	7.5	5.6	TEFC	575	8.8	60	3	EC
MIXER	1.75	1.3	TEFC	575	2.4	60	3	EC
AUGER	10	7.5	TEFC	575	11	60	3	EC
AUGER	7.5	5.6	TEFC	220/380-415	22/12.7-11.6	50	3	STD
MIXER	1.75	1.3	TEFC	220/380-415	5.9/3.4-3.1	50	3	STD
AUGER	10	7.5	TEFC	220/380/415	28/16.2/14	50	3	EC

EC = Extra Cost NC= No Charge STD = Standard

Switch: Watertight magnetic with thermal overload and under voltage protection.

Power Cord: 12' #10 GA- 4 strand cord with plug 7.5 hp, U.S.,
12' #10 GA - 4 strand cord no plug 7.5 hp International(50 Hz/575V)
12' #8 GA - 4 strand cord with plug 10 hp U.S.,
12' #8 GA - 4 strand cord no plug 10 hp International(50 Hz/575V).

Hopper Capacity: Hopper: 200 lbs. (91 kg).

Grinding Capacity: Output – up to 65 lbs.(29.5 kg) per minute.

Drive System: Auger: Single reduction (35 pitch – 4 row) roller chain drive with tapered roller bearings.

Mixer: Heavy duty mixer motor interface drive system.

Safety: Magnetic safety interlock on hopper lid.

Standard Features: Stainless steel 2nd grind paddle with center arms
• 5" Dia. total lock swivel casters with anti-microbial wheels • spurt guard • extra rod for front, left or right side opening lid • power cord (see above) • ring wrench • bowl nut wrench • two shear pins with screws • Receptacle for electric footswitch •operating and safety manual.

Options (NC): Size 52 right hand 35 ° hopper feed inlet (see drawing).

Options (EC): Size 32 plate and knife • single-reduction “Eagle” self-centering, no stretch, no lubrication, poly belt auger drive • electrical or pneumatic footswitch • accessory cleaning and storage rack • extra long stainless steel legs (33”(838 mm) to 42”(1067 mm)) from floor to bowl center • Size 52 left hand 35 ° hopper feed inlet • connections for tandem operations • 10 hp (7.5 kw) auger motor • stainless steel bowl, ring and auger (Enterprise or Unger Style).

Certification: U.S.D.A., U.L., N.S.F., C.S.A. on 7.5, 208/230/460-60-3

Weight: Uncrated: 683 lbs. (310 kg) approximate.
Carton packed: 789 lbs. (358 kg) approximate.
Wood crated: 887 lbs. (402 kg) approximate.

Dims Crated: L=50” (1270mm), W=36” (914.4mm),
H=66” (1676mm)

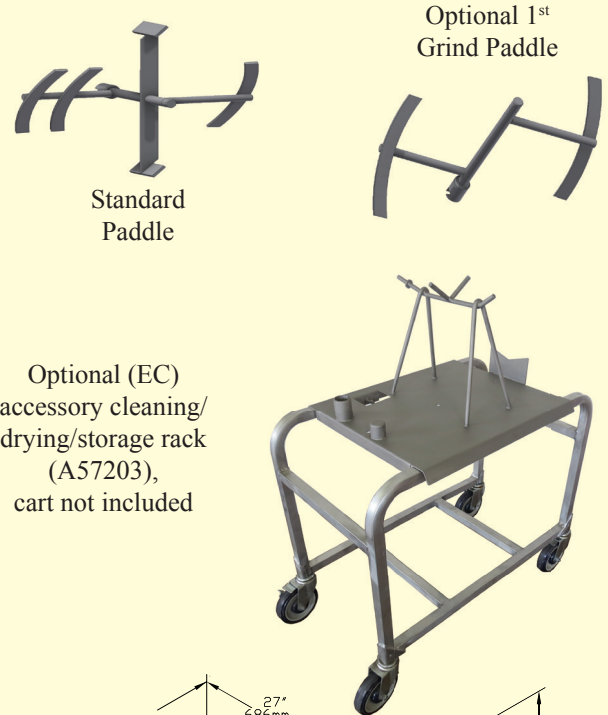

Optional (EC) accessory cleaning/drying/storage rack (A57203), cart not included

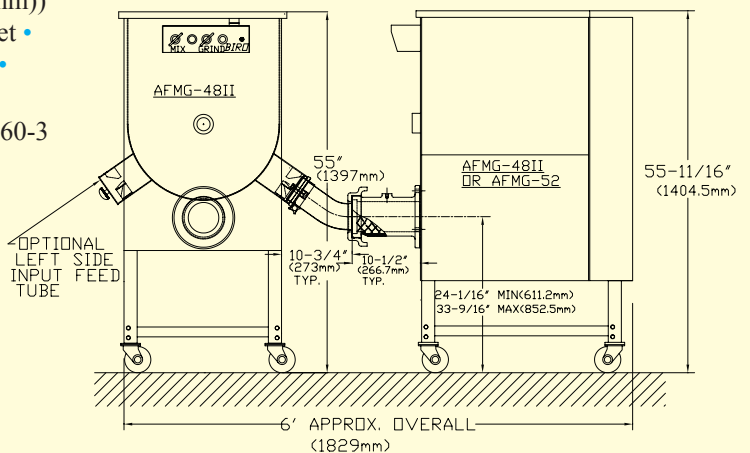
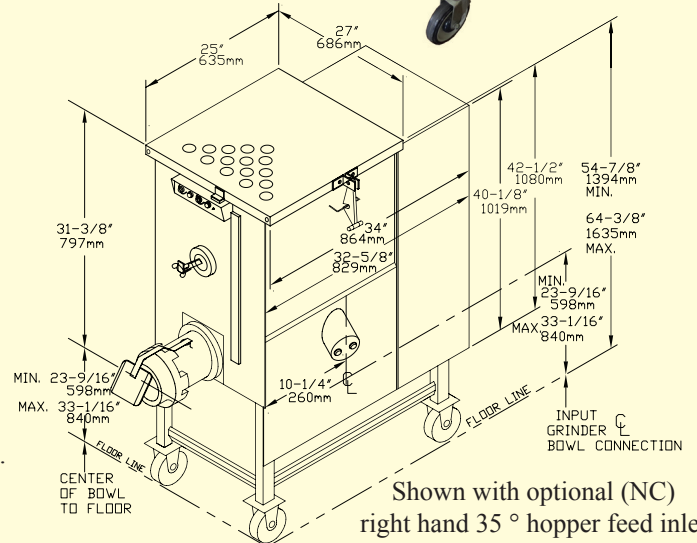

Tandem Operation- AFMG-48-II or AFMG-52 to AFMG-48-II

BIRO MANUFACTURING COMPANY
1114 WEST MAIN STREET

MARBLEHEAD, OH 43440-2099 U.S.A.

Phone: (419) 798-4451 <http://www.birosaw.com>

Fax: (419)798-9106 sales@birosaw.com

All specifications contained herein are subject to change without notification.

ITEM NO.: LIT-AFMG48-123
FORM NO.: Md AFMG48-123-6-14-8-B

Service is available from locations worldwide